



# SOCKET MOUNTED FACEWASH w/ DRENCH HOSE PART NUMBER: 01090102

**SPECIFICATION:**

Third party certified to ANSI Z358.1, the eye/facewash/drench hose unit shall deliver 8.0 gpm (30.3 lpm) @ 45/70 psi (310.6/482.6 kPa) of flowing pressure. Unit shall provide a non-injurious stream of water for 15 minutes or longer. Unit shall be supplied with ½” chrome plated (CP) single motion activation stay open ball valve with CP ball. Unit shall include SS actuator with actuation graphic, 6-foot (182.9cm) coiled drench hose, wall bracket and 7” X 11” (17.8cm x 27.9cm) sign. Unit shall be supplied with 8.0 gpm (30.3 lpm) regulator to assure a constant and even dual stream flow pattern under 45/70 psi (310.6/482.6 kPa) hydraulic conditions. Eye/Facewash heads and float off covers to be manufactured of UV resistant ABS plastic. Float off covers are secured with stainless steel bead chains and provided to inhibit dust and/or contamination when not in use. Eye/Facewash/drench hose units with deteriorating screens/filters are not acceptable. **Encon Safety Products model 01090102** includes socket mounted facewash/drench hose unit.

**\*Note:** Where hazardous materials that are injurious to the skin are used, a proper eyewash or eye/facewash installation with an emergency shower should be considered.

**MATERIALS OF CONSTRUCTION:**

**VALVE:** ½” chrome plated bronze stay open ball valve with chrome plated ball, stainless steel valve stem and stainless steel push plate with actuation graphic.

**HEADS:** ABS plastic dual stream heads with ABS plastic float off covers secured with stainless steel bead chains and chrome plated wye assembly.

**HOSE:** 6’ (182.9cm) coiled hose.

**REGULATOR:** Self-adjusting (2) 4.0 gpm (15.1 lpm) regulators.

**SUPPLY:** ½” NPT

**WEIGHT:** 6 lbs (2.72 kgs)

**PRESSURE:** Requires 45 psi (310.6 kPa) flowing pressure.

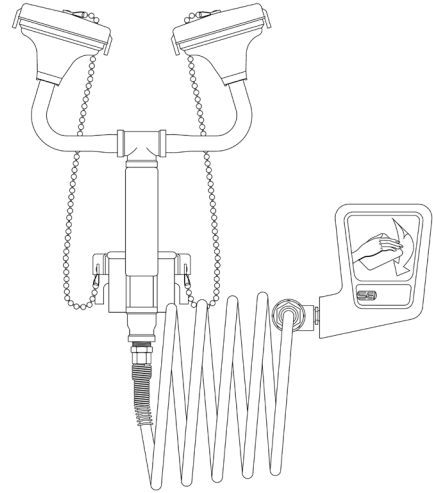

FRONT VIEW

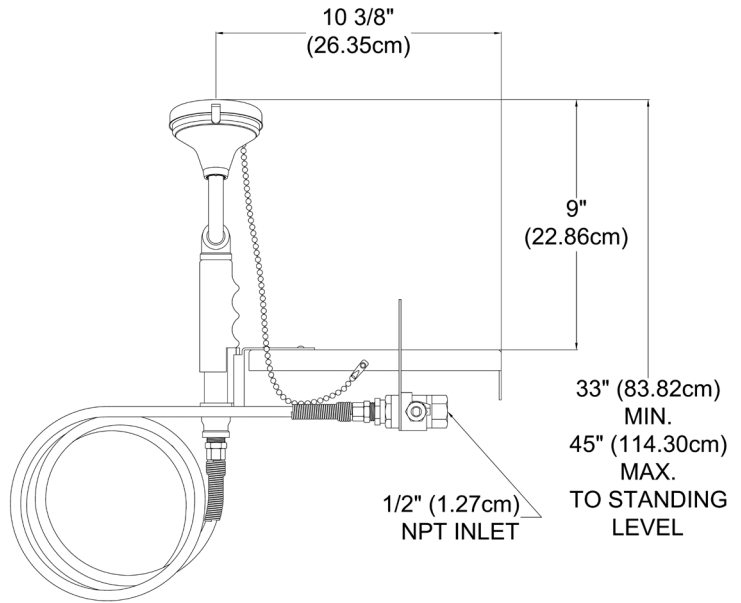

SIDE VIEW