TEMPERED WATER

Solutions
for Safety
Showers



A company with experience...

With more than 50 years of experience as a manufacturer of quality safety equipment, Encon® has earned a reputation for providing reliable, innovative products to protect personnel and provide emergency treatment. Encon's superior designs offer pre-engineered and customized options to fit the needs of our client's specifications and applications.

Our internal staff of manufacturing professionals, with their years of experience, results in superior craftsmanship of safety products. Continuing the company excellence is our team of R&D, Manufacturing Engineers and Customer Service Staff who are willing to go the extra mile for our customers to provide them with the best solutions.

Built to strict standards...

Shower stations don't always create complete compliance by themselves. One of the main components to becoming compliant to the ANSI/ISEA standard is tepid water. Encon designs and fabricates a multitude of systems to fit your needs for tepid water delivery. With consultation and on-site surveys, we can help establish proper installation, use, and service of safety equipment. Encon's products and services meet or exceed all regulations and expectations by following strict, exacting standards making Encon the clear choice for solutions to be compliant.

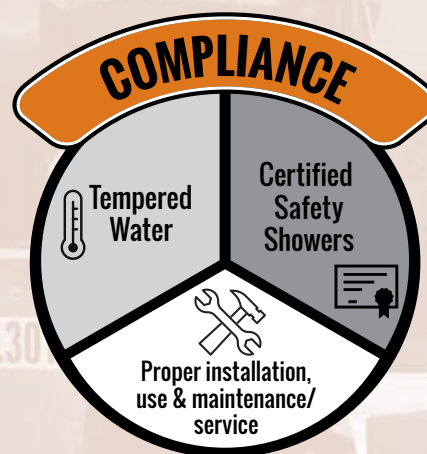

BLENDING

When you only have a single source of plumbed water and it is not at the right temperature for tepid compliance, what do you do? Encon's solution is blending. Supply water is blended with stored heated/cooled stored water or instantaneously heated water to create tepid water that is then supplied to the safety shower stations. All of this happens with Encon's electrically-controlled, fail-safe blending systems.

Storage Vessel Systems

- Water is stored in a standing vessel
- Heating option uses a thermostat-controlled immersed heater to raise the stored water temperature for blending with the cold supply water
- Cooling option lowers the stored water temperature using a chilling system for blending with the hot supply water
- Indoor and Arctic[®] freeze-protected outdoor models are available



STORAGE VESSEL SYSTEMS

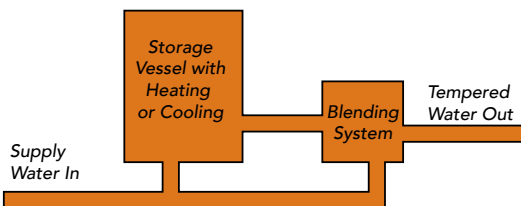

(Above) Cooling system including a cold water storage tank, blending system, over-temperature controls, relief valves, and recirculation and booster pumps. Skid mounted for use in above freezing environments.



STORED WATER HEAT/COOL TIMES

Heat/Cool	Vessel Size	Time
9 KW Heater	120 Gallon	4 Hrs
9 KW Heater	300 Gallon	10.5 Hrs
6.3 KW Heater	120 Gallon	6 Hrs
6.3 KW Heater	300 Gallon	15 Hrs
3 Ton Chiller	400 Gallon	5 Hrs

(Left) Heating system including a hot water storage tank, blending system, over-temperature controls, relief valves, and dual recirculation and booster Pumps. Skid mounted for use in above freezing environments.

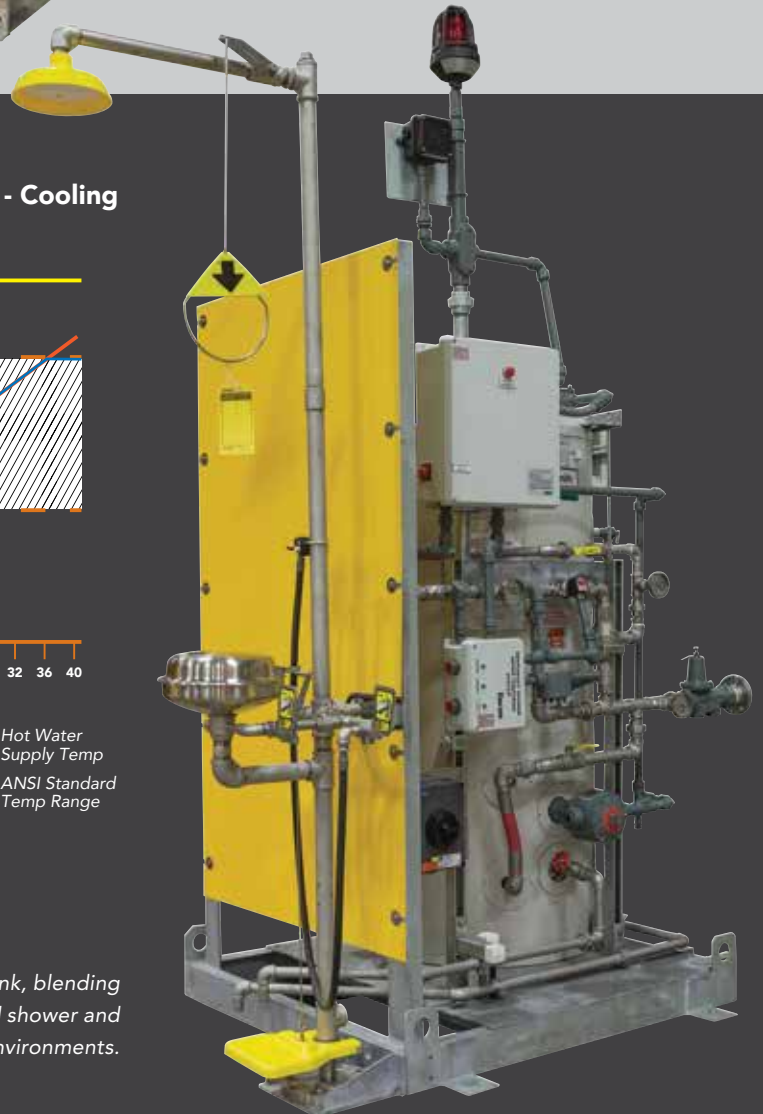

Blending Systems - Heating

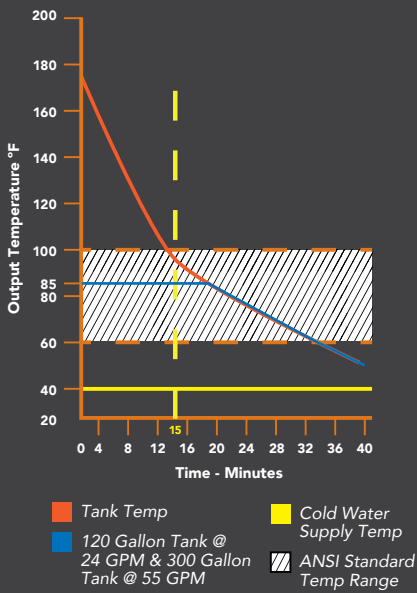

Blending Systems - Cooling

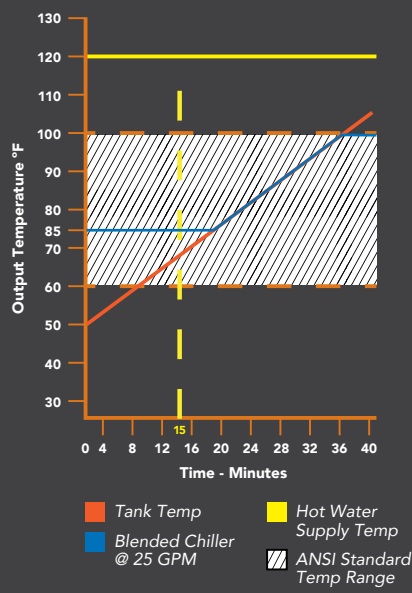

(Right) Heating system including a hot water storage tank, blending system, over-temperature controls, relief valves, and shower and eyewash. Skid mounted for use in above freezing environments.



(Front view with door closed)

Instantaneous Systems

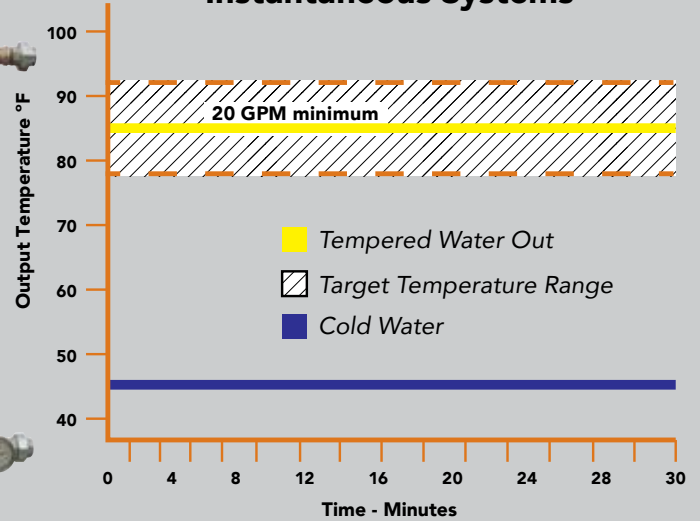

Electrically heated instantaneous system with floor mounting flanges. Includes a thermostatic-controlled hot water purge for over-temperature protection, cold water bypass, and an air heater for freeze protection.

Instantaneous Systems

- Water is passed through a steam or electric exchanger and instantaneously heated for blending with cold supply water
- Offers the lowest per-shower cost for multiple or simultaneous operation



(Front view with door open)

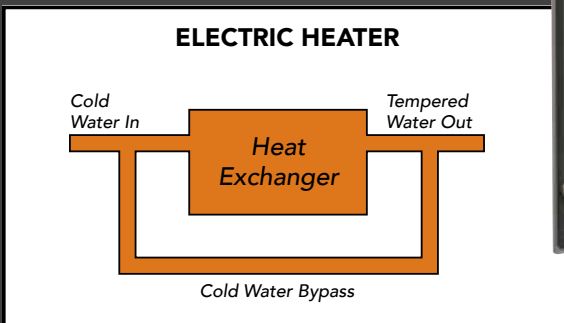



(Front view with access door open)

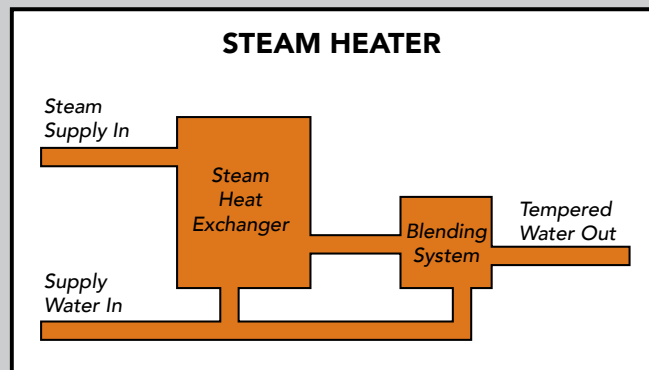

Instantaneous system including a steam exchanger, a blending system, cold water bypass, and over-temperature control.

Enclosed in a UV inhibited fiberglass structure with an internal room heater for freeze protection. This model includes recirculation pumps and booster pumps sized for the application.

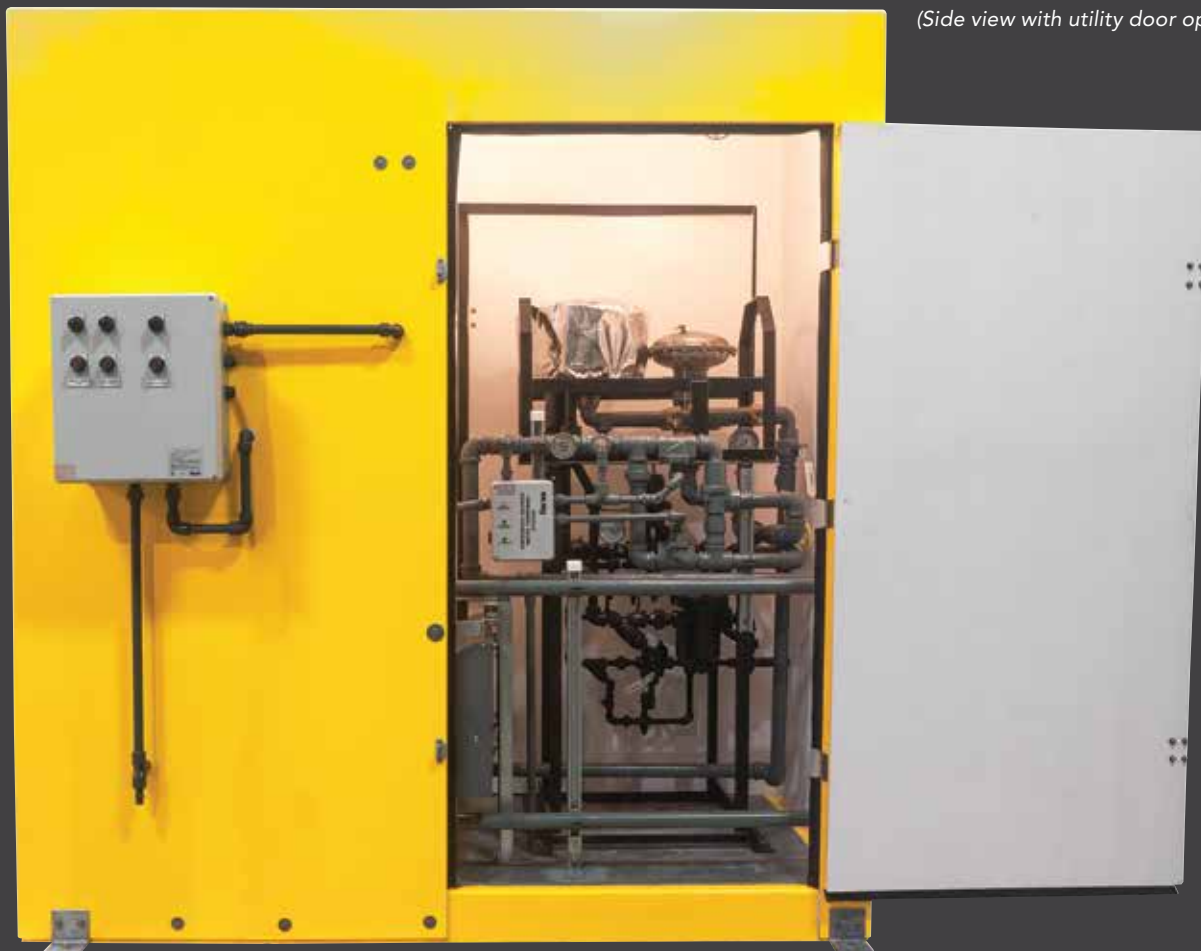

(Side view with utility door open)

SELF-CONTAINED

Encon's self-contained tempering systems provide the tepid water solution when your application is remote or doesn't have a readily available plumbed water source. These stand alone units have a "fill and close" method with simple, turn-key designs making them low maintenance and easy to operate. A self-contained system stores flushing fluid at temperature for delivery to safety shower stations to meet compliance requirements.

Gravity Fed Systems

- Flushing fluid is stored in an overhead vessel
- System is gravity fed with no additional pressurization source needed for evacuation of flushing fluid
- Stored fluid temperature is maintained at 90°F by means of heating or cooling
- Models are available with or without side panels and doors for indoor applications and enclosed freeze protected with a room heater for outdoor applications
- Provides 15 minutes of flushing fluid for simultaneous use of the included shower and eyewash station
- Conveniently include a level gauge on the vessel to monitor the internal fluid level, and a Hydrosep Injector at the water inlet to bring in the water additive as the tank is filled

(Right) Gravity fed system including an overhead tempered water storage tank, over temperature control, and a shower and eyewash. This model is enclosed with UV inhibited panels and an internal room heater for protection against freezing.



(Right) Air driven system including a tempered water storage tank, over-temperature control, relief valves, a shower and eyewash. Walk-on skid with floor drain. This model is customized to include yellow corrosion resistant coating.



Air Driven Systems

- Flushing fluid is stored in a standing vessel
- Stored water temperature is maintained at 90°F by means of heating or cooling
- Air distribution system includes air cylinders, stainless steel tubing, and pressure regulator to pressurize the system for use
- Indoor and Arctic® freeze-protected outdoor models are available
- Provides water capacity sufficient for 15-minutes of flow to the included shower & eyewash station
- A Hydrosep Injector located at the water inlet allows the water additive to be proportionately injected during tank fill

(Right) Air driven system including a tempered water storage tank, over-temperature control, relief valves, a shower and eyewash. Skid mounted for use in areas above freezing temperatures.



STORED WATER HEATING TIMES

Heater	Vessel Size	Time
2 KW	400 Gallon	16 Hrs
6.3 KW	400 Gallon	5 Hrs
9 KW	400 Gallon	4 Hrs
2 KW	450 Gallon	18 Hrs
6.3 KW	450 Gallon	6 Hrs
9 KW	450 Gallon	5 Hrs

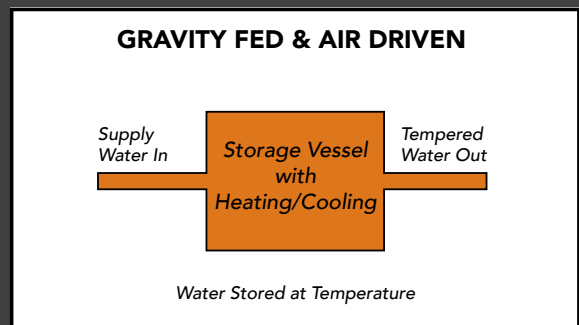
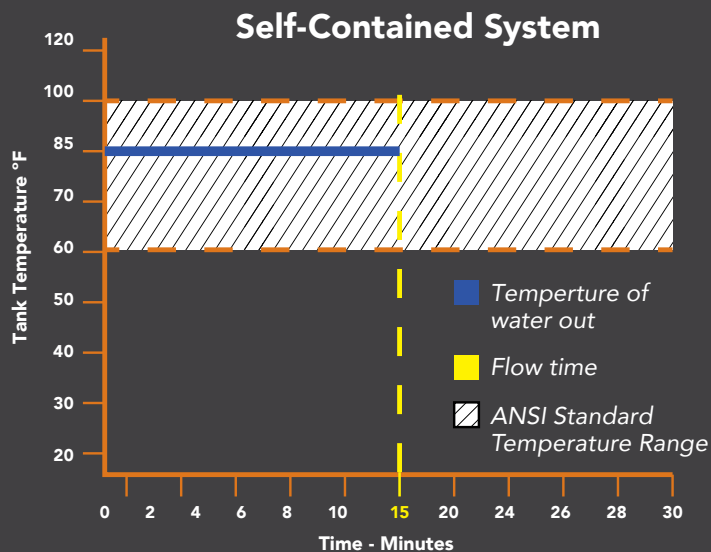

OUTDOOR

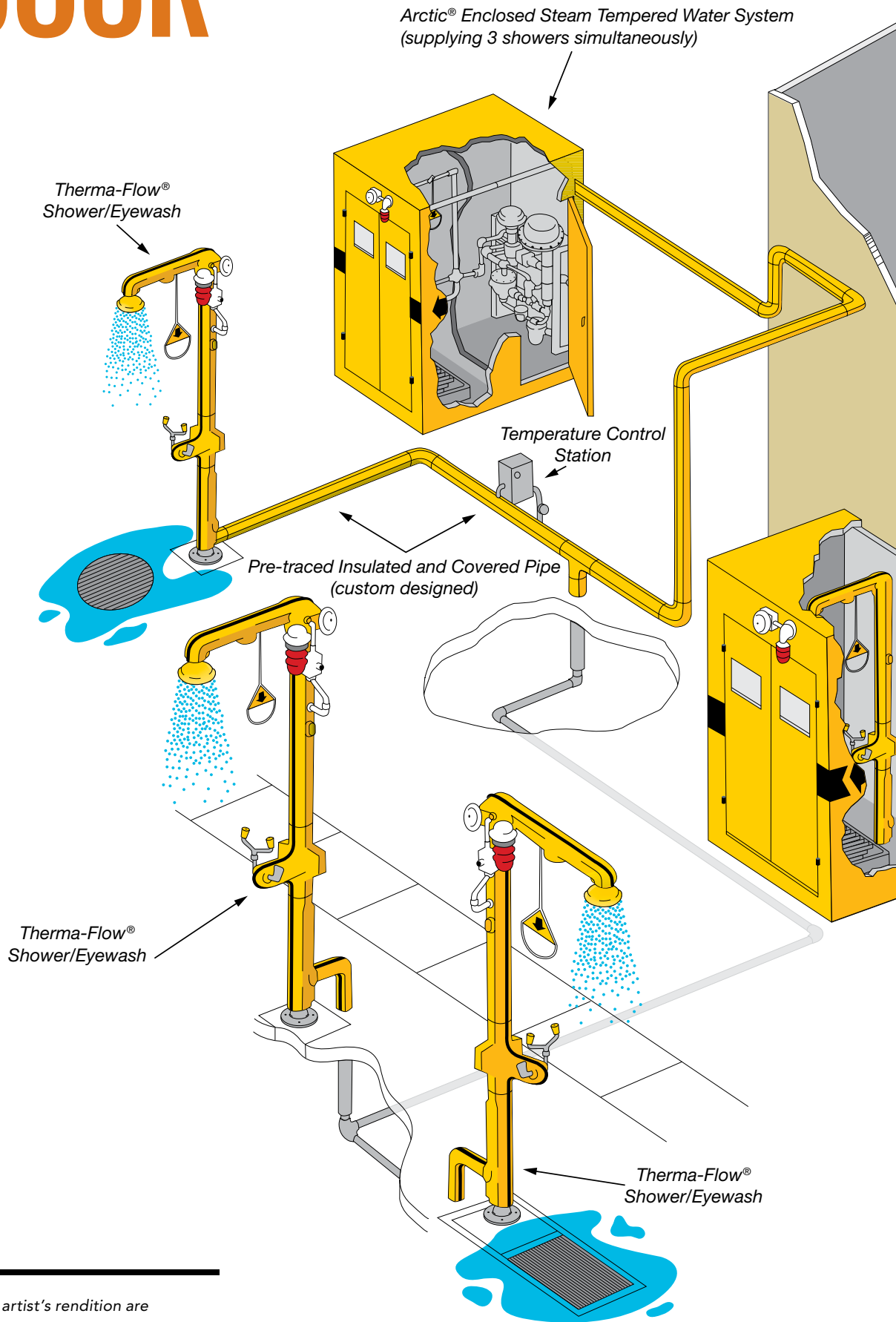

Note: The products shown in this artist's rendition are designed to depict the concepts illustrated and are not necessarily technically accurate.

INDOOR

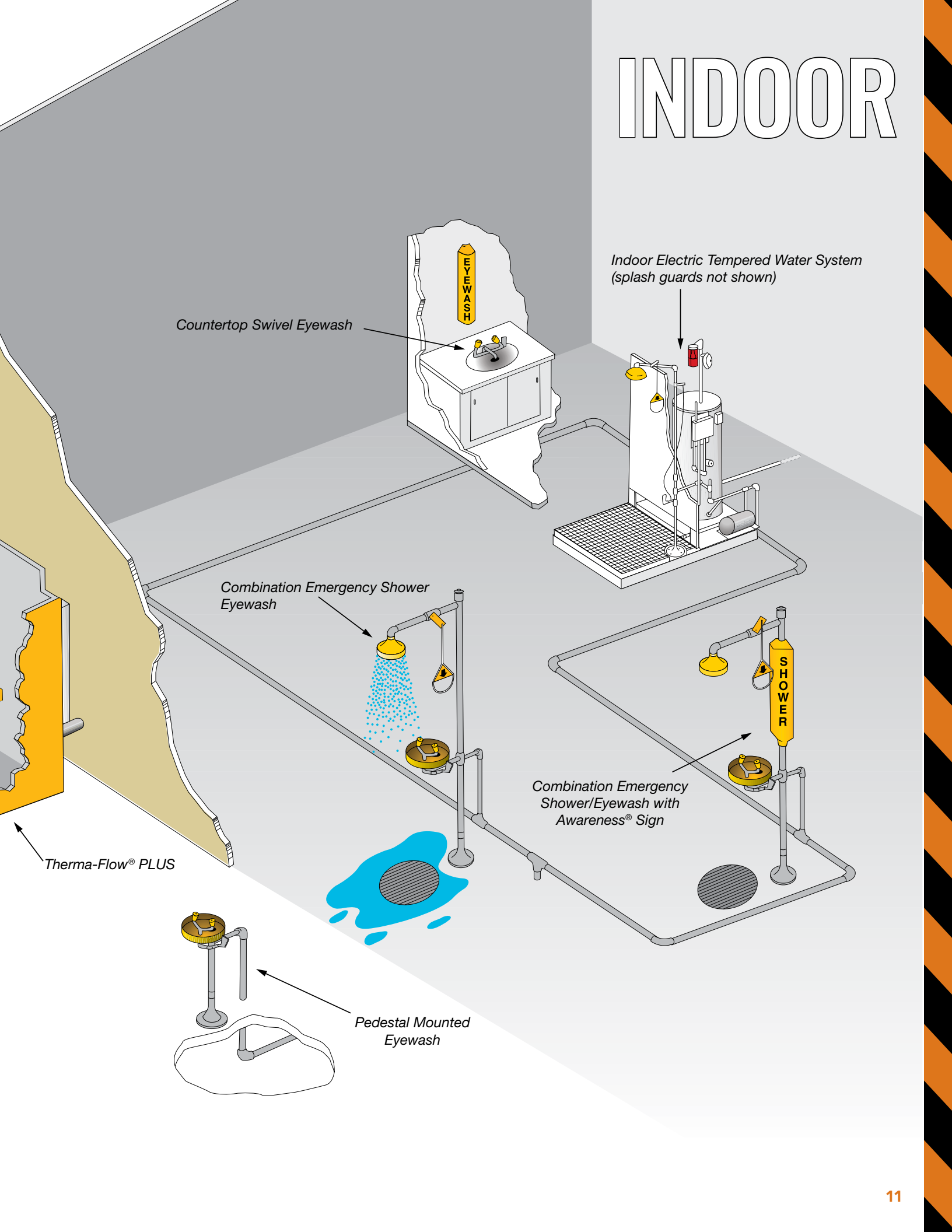

Instructions

To generate a Model, select one item from each position, filling all 15 position digit boxes. For further assistance in Model Selection, Product Pricing or Application Assistance, contact Encon Customer Service Representative at 1-800-283-6266.

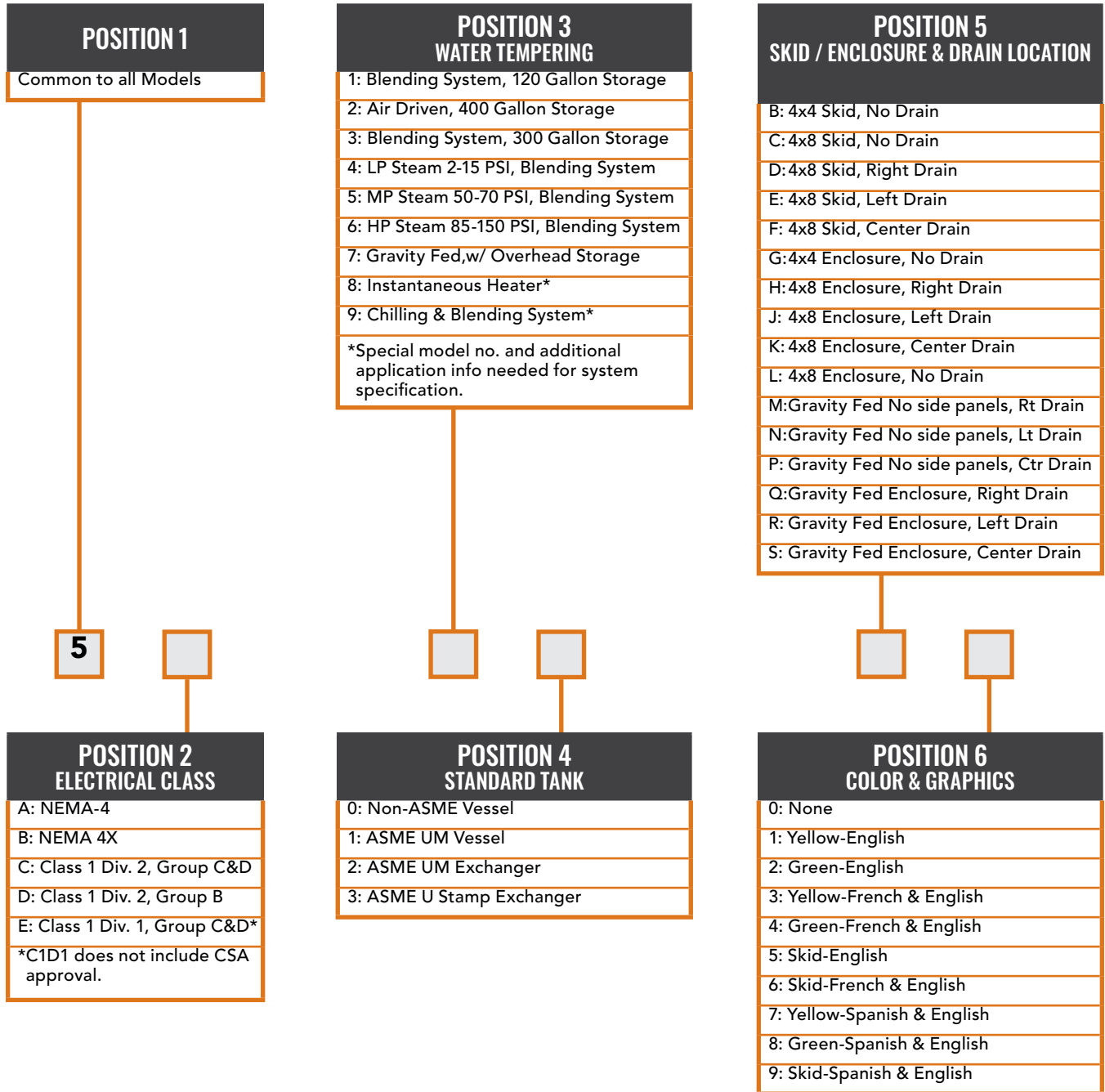

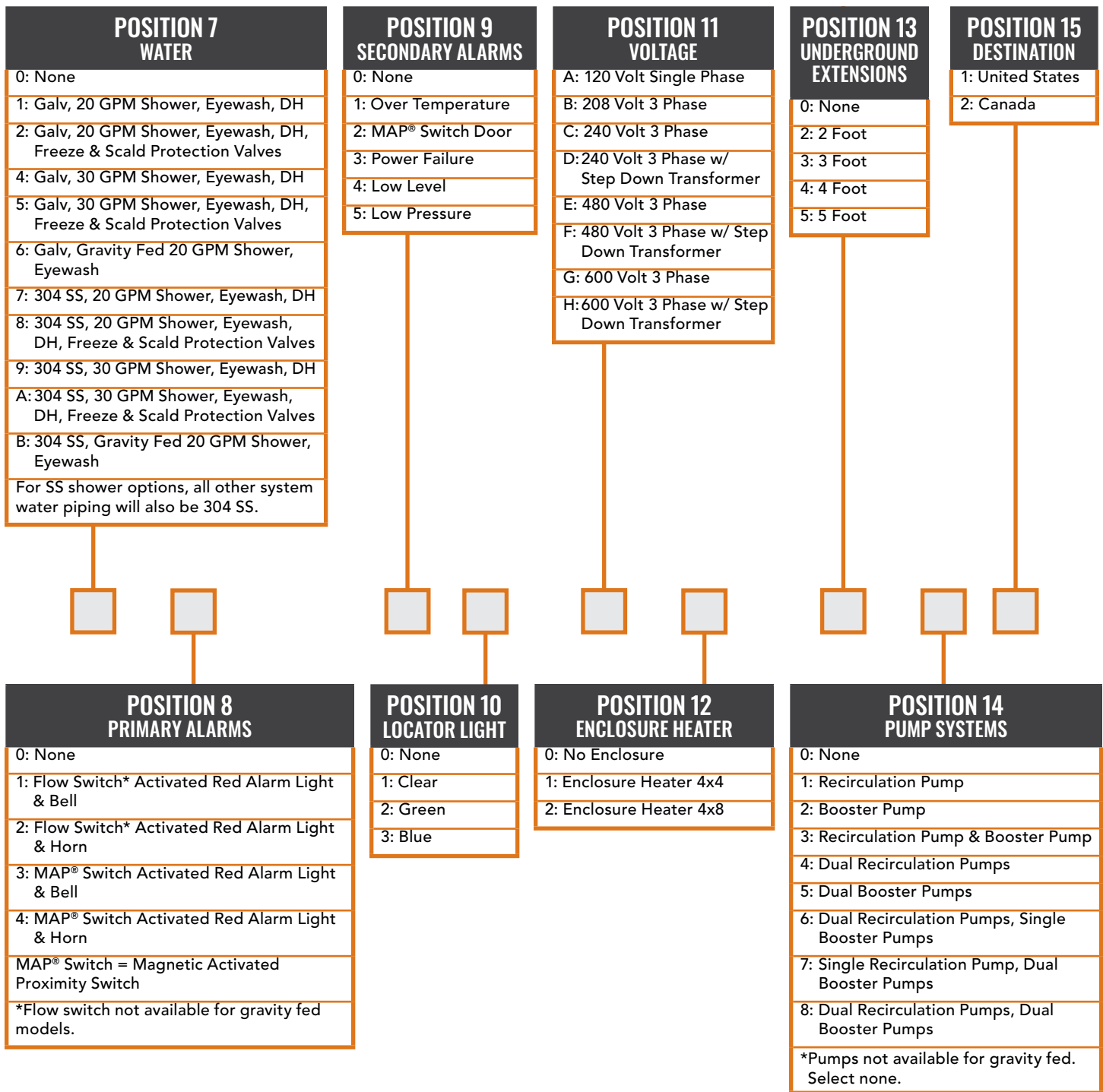

Notes

Position 5 - When an enclosed option with no drain is selected, a shower cannot be selected.

Position 7 - Drench hose is automatically not included with 120 & 400 gal systems. A special model number is needed when drench hose is required for these systems.

Position 10 - Locator light is separate from alarm light.

Position 13 - Dimensions reference length of pipe below grade.

Application Information Sheet

Please fill out this form and email it to an Encon® Representative - customerservice@enconsafety.com

Customer Information

Date: _____ Date Required: _____

Company: _____

Contact: _____

Address: _____ City: _____ Country: _____

Plant Location: _____ Telephone: _____ Email: _____

Facility Information

Hazard: _____

Low Temp: _____ Operative Temp: _____ High Temp: _____

Supply Water Temps

High: _____ Low: _____ Normal: _____

Utilites

Supply Water Pressure (Dynamic) @ GPM: _____

Electrical Voltages Available: _____

Steam Pressure Available: Y / N Steam Temp: _____ Length of Recirc. Loop: _____ Max. Elevation: _____

Supply Line Pipe Size: _____ Pipe Material: _____ Pipe Schedule: _____

Is there an Isometric Drawing available of the facility that can be used by Encon? _____

Equipment Specification

Number of Stations

Showers: _____ Eyewash: _____ Facewash: _____ Drench Hose: _____

Electrical Classification:

- NEMA-4
- NEMA-4X
- Class 1, Div. 2, Group C&D
- Class 1, Div. 2, Group B
- Class 1, Div. 1, Group C&D
- Others (Define on application)

Area Lighting:

- Plant Supplied
- Supplied with TWS

Desired Area Light Color:

- Green
- Clear
- Blue
- None

Alarm Systems:

- Local
- Remote (3 amp)
- Audible
- Visual

Temperature (AIT) Classification: _____ Freeze Protection Required?: Y / N

Further Information For Review:

Equipment Installation & Space Requirement Data

4' x 8' Arctic® Building

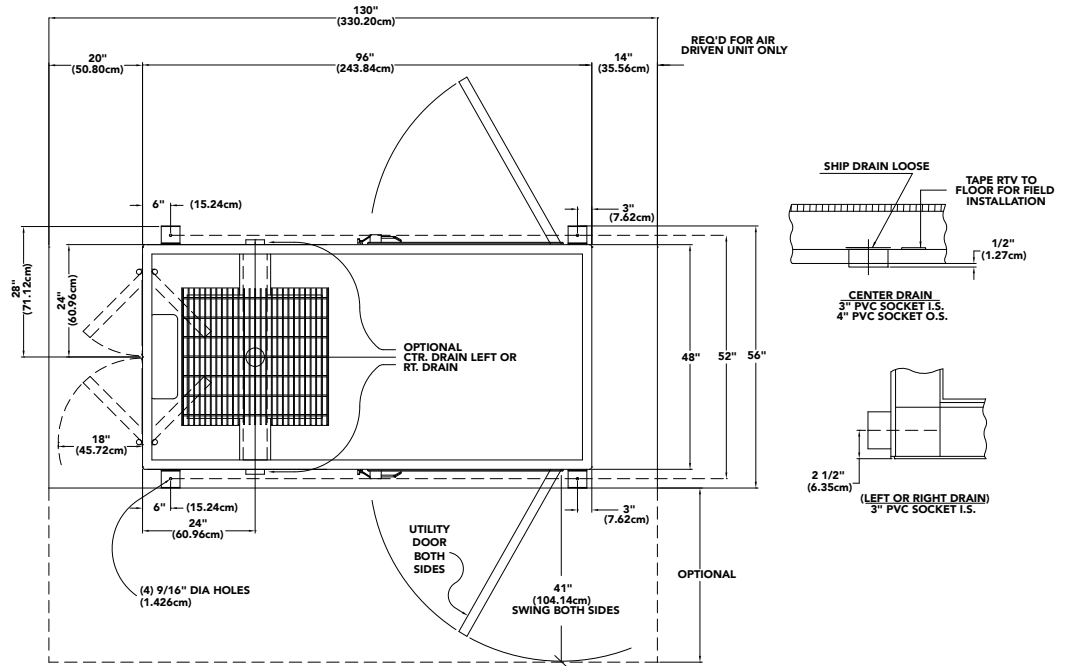

4' x 4' Arctic® Building

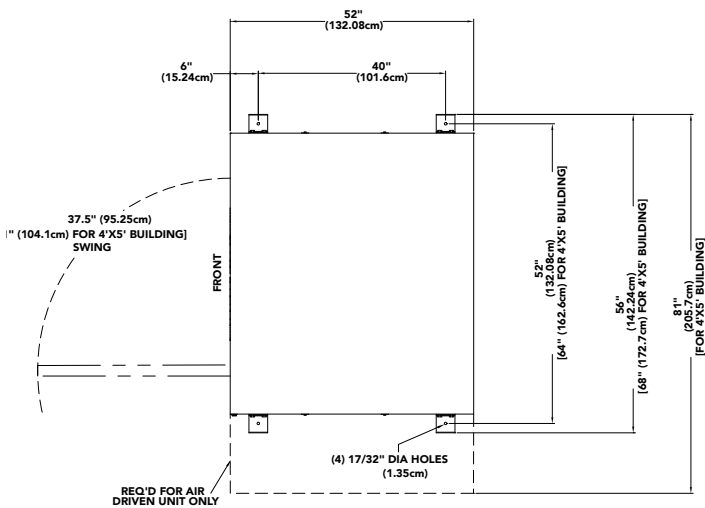

4' x 8' Skid

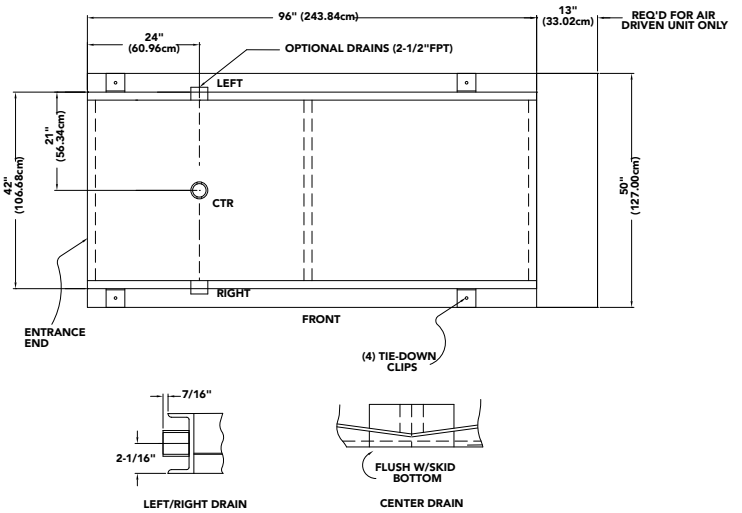

4' x 4' Skid with Shower Base

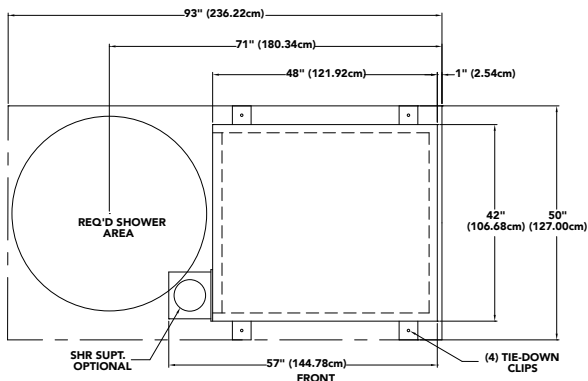

4' x 4' Skid

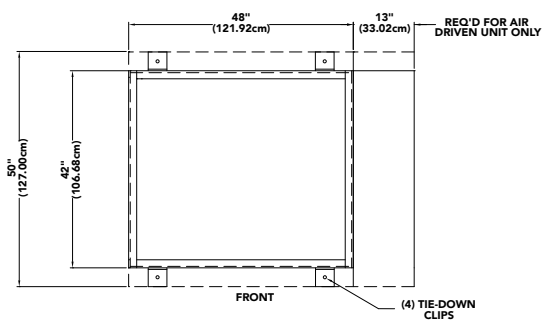



**6825 West Sam Houston Pkwy., N.
Houston, Texas 77041**

www.enconsafety.com

**Ph: 713.466.1449
1.800.AT.ENCON
(1.800.283.6266)**

customerservice@enconsafety.com

